



TRACER 2™

MODULAR MOISTURE ANALYZER

Known for the most advanced – and- practical moisture analyzers, MEECO proudly introduces the second generation of our popular TRACER modular moisture analyzer and our fifth generation of parts-per-billion (ppb) detectors. The TRACER 2 offers more alarms and new options than its predecessor, while retaining all of the features that made the TRACER the moisture analyzer of choice.

With its unique design concept, the TRACER 2 pairs parts-per-billion (ppb) detection with fast response time. Plus, it is easy to use – hook it up and with a few keystrokes, you’re ready to go. So, whether you use a stationary analytical rack or a portable cart, the TRACER 2 has the sensitivity and quick response required to eliminate moisture as a yield detractor.



We can say this because the TRACER 2 takes MEECO’S time-proven technology to the next level. Drawing from a fundamental principle of physics, Faraday’s Law, the TRACER 2 measures moisture through electrolysis. The electrical current generated relates directly to the moisture concentration in your gas. And, because it relies on an absolute measure, the TRACER 2 requires no sensor calibration. Simply verify your flow and current, and you meet the documented procedure for ISO 9000. Your TRACER 2 can stay online all the while!

A simple, robust design, combined with patented moisture-addition technology, make the TRACER 2 the most flexible moisture analyzer available. The unit itself is so compact that we can offer two devices in one standard panel-mount case, the TRACER 2 DUO. This feature not only saves space, but also permits you to measure two gas lines at a time. The TRACER 2 is designed to be more reliable, easier to use, and to offer greater value than any system on the market.

VALUE BY DESIGN

The TRACER 2 addresses the need for accurate, reliable process controls, and moisture sampling at levels at or below single-digit ppbs. Its operation draws upon highly sophisticated concepts, enabling us to offer you:

- **Modular configuration.** The first thing you'll notice about the TRACER 2 is that it's less than half the size of a conventional, rack-mount analyzer. Package two units side-by-side in one standard 19-inch rack mountable box and you have a TRACER 2 DUO. Not only does the economical TRACER DUO save on space, but it allows you to monitor two sample lines at a time or to have a handy back-up unit if needed. Alternately, you can combine a TRACER 2 with any other instrument that fits in the space drawer provided with every unit.

The Tracer 2 gives you the quick response required to maintain the UHP levels of your gases. Proximity of the sample system to the sample gas, low dead-volume regulator, improved electronics-all contribute to performance. On both wetting and drydown, field reports verify as much as two-fold improvement in speed compared to its predecessor, the Tracer, the industry leader for half a decade.

- **High Performance.** The TRACER 2 gives you the quick response required to maintain the UHP levels of your gases. Proximity of the sample system to the sample gas, low dead-volume regulator, and improved electronics - all contribute to performance.
- **Low cost ownership.** Highly reliable, the TRACER 2's unique new flow system does not require permeation tubes, complex manifolds or compressed air. Maintenance costs are further curbed by the minimal number of components used. In addition, its rugged design and easy access to the cell, the pressure regulator and the microprocessor board improve service and minimize downtime. The TRACER 2 is available when you need it – the ultimate goal!
- **Ease of operation.** The TRACER 2 arrives ready to use from the factory. All you need to do is: Check the pressure, select your gas type and go! No need to shut down your process, break the line for installation or follow complicated procedures.

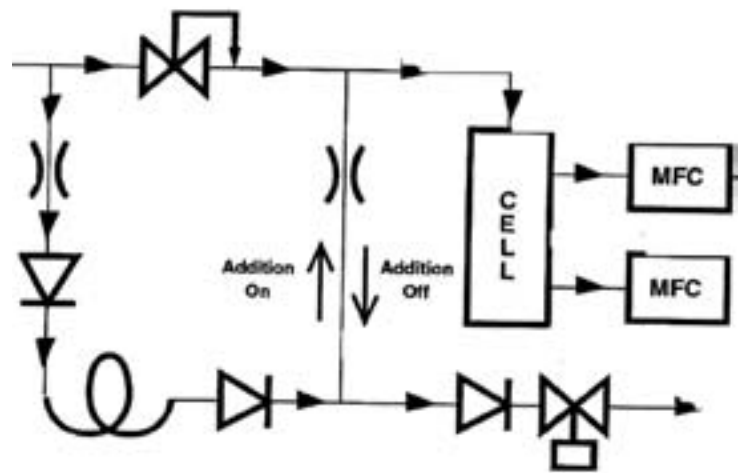

- **Portability.** Ideal for carts in particular and transport in general, the TRACER 2 is lightweight and built to sustain mechanical shock. Plus, there's no need to restabilize, reset, recalibrate or in any way reconfigure the TRACER 2 when you move from point to point, the unit continues to monitor in real-time, without delay. The TRACER 2 embodies the mechanical integrity associated with MEECO instruments for decades.
- **Communication.** An RS-232 serial communication port allows you to connect to any PC with an RS-232 port.
- **Service in Real-time.** MEECO offers diagnostic tools for on-line service and maintenance. Simply connect your TRACER 2 to a computer and using our diagnostic software, we can obtain your operating parameters on-line.

VALUE IN THE MARKET

MICRO magazine cited moistures as the “most significant contaminant in semiconductor process gases,” going on to explain, “Moisture can cause particle formation and may result in electrical property defects that diversely affect device yields.” The problem becomes all the more pronounced, MICRO states, as “line width shrinks and more process steps are required.” This growing need is compounded by a concern with cost of ownership. In both features and price, the TRACER 2 fits the bill for:

- **Semiconductor manufacturing.** Moisture specifications at the single-digit ppb range are now the norm; the TRACER 2 performs this measurement reliably. In addition, as its name implies, the TRACER 2 detects leaks within the process, affording considerable savings in potential lost yield.
- **Inert and specialty gases.** The TRACER 2 detects moisture contamination in all major semiconductor process gases: Nitrogen, Argon, Helium, Hydrogen and Oxygen. Handled properly, it also measures moisture in many Electronic Specialty Gas (ESG) applications, Neon, Xenon, Sulfur, Hexafluoride, and Carbon Tetrafluoride among them.
- **Component and system testing.** The TRACER 2 registers speed and level of dry-down for systems, components, and tools. The TRACER 2 verifies the performance of purifiers; helps correlate between moisture content and product yield; and checks the validity of other instruments, such as APIMS.
- **Laboratory research.** Given its repeatability and absolute technology, the TRACER 2, like its predecessor, is ideal for on-going research to determine the relevance of moisture content to wafer yield in various processes.
- **Other Applications.** Unique circumstances can necessitate ppb moisture analysis in various industries, including Pharmaceuticals, Electric Power, Refrigeration, Chemical and Petrochemicals, and Natural Gas Processing and Transmission.

VALUABLE BENEFITS

Based on our many years of experience, working closely with those engaged in high-purity moisture analysis, MEECO designed features that address your unique needs for:

FEATURE	BENEFIT
Ease of Use	“Plug and Play” operation based on menu-driven microprocessor control. Its single branched menu allows you ready access to all variables, including start-up, and shutdown procedures on-line.
Non-Invasive Sensing	No danger of interference with or contamination of your process. (Filtration and other types of installation are a leading cause of upsets.)
On-Line Response Checking	Continuous assurance that your unit reacts to moisture changes at very low levels.
Remote Monitoring	Feed into your own process control computer via RS-232 serial interface.
NIST Certification Test Reports	NIST Certification Test Reports
	Annual Performance Certification at our factory or your site.
Temperature Stability	Short cycle times results in low sensitivity to temperature changes.
Service Programs	MEECO offers a comprehensive service program in support of the TRACER 2 and other instruments. This includes installation and start-up, operational training and troubleshooting assistance. We also offer in-field and in-house maintenance and recertification of our instruments as part of an ISO or other quality programs.

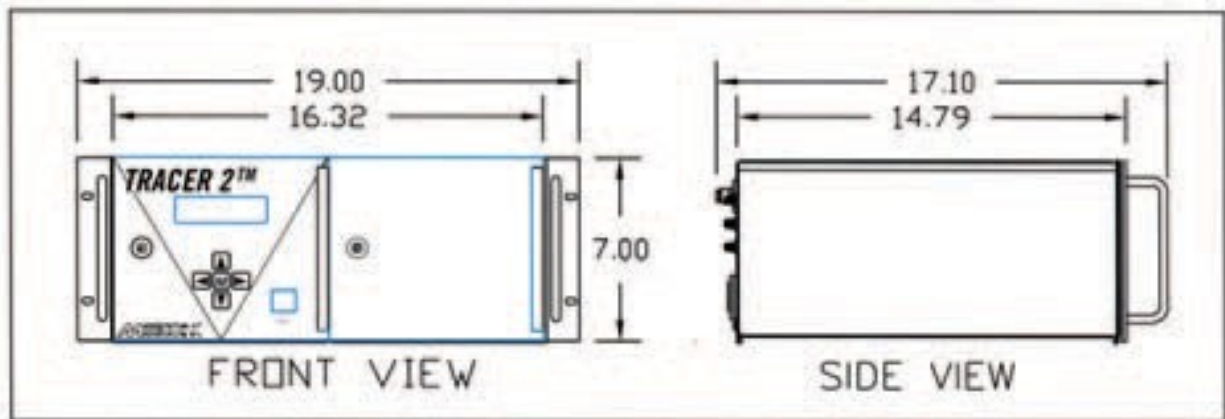

VALUE ENGINEERING

The TRACER 2's state-of-the-art performance derives from its:

- **Absolute technology.** Based on Faraday's Law of Electrolysis, the TRACER 2 sensor absorbs and electrolyzes moisture down to fractional ppb's. How? One hundred percent of the sample moisture is absorbed by a phosphorus pentoxide (P_2O_5) film that covers two spirally wound electrodes embedded in a hollow glass tube. (See Figure 1.)
- When the sample gas enters the cell at a known flow rate, the film absorbs all the moisture molecules present. By applying an electrical potential (voltage) to the electrodes, each absorbed water molecule is electrolyzed, generating an exact current. (See Figure 2.) This current is precise and proportional to the amount of absorbed water. It is, therefore, an exact, direct measurement of the water vapor present in your sample gas. (See Figure 3.)

Therefore, once equilibrium is reached, the generated current equals the rate at which the molecules are electrolyzed.

MOISTURE IN = CURRENT OUT

Thus, if the electrical current and the gas flow rates are accurate (both easy to measure and to verify on-line), you determine the correct moisture content. This is particularly helpful at very low levels, where attempts to calibrate sensors with known moisture concentrations are as difficult as they are dubious.

- **Fast response time.** MEECO's method of controlled moisture addition (U.S. Patent No. 5199295) speeds response time. In effect, it actively sweeps moisture to the cell, which reduces the wetting time and increases the cycle rate of the sensor.
- **Prolonged sensor life.** MEECO's time-proven, patented method of maintaining sensor performance in very dry gases assumes a new, less expensive and yet more effective guise. Simple plastic tubing permeates atmospheric moisture to the cell in a highly controlled fashion. Note: The actual moisture measurement occurs when the moisture addition is suppressed by a counter flow through a small orifice. Further, check valves protect the cell in the absence of a gas flow, such as during shipping. (See Flow System)
- **Low levels of detection.** By modulating the flow through the cell, the improved signal allows the TRACER 2 to detect moisture at exceptionally low levels.

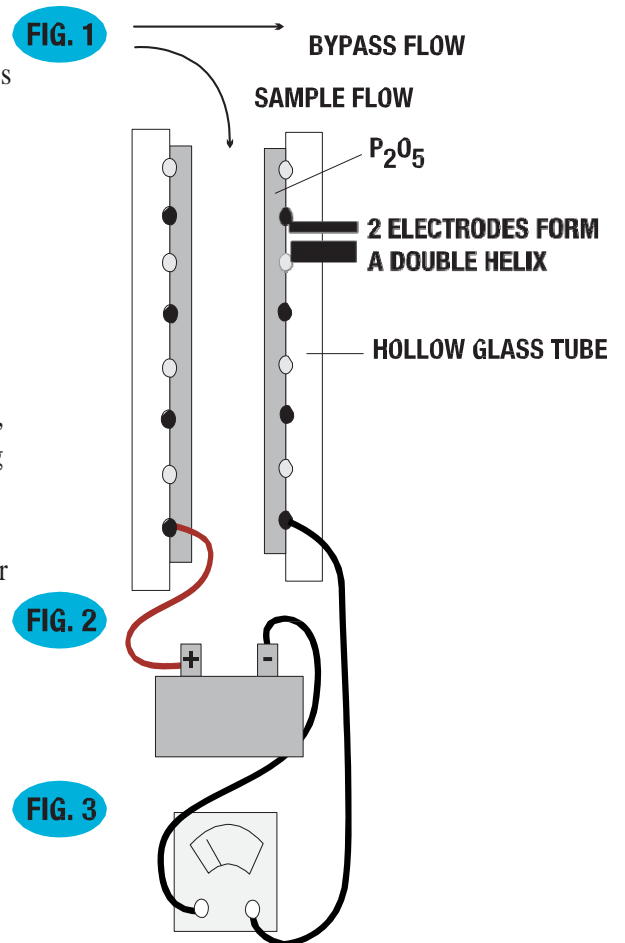

SPECIFICATIONS*

Operating Range:	Inerts: 0-2000 ppb Oxygen: 0 – 1200 ppb Hydrogen: 0 – 500 ppb
Sensor:	MEECO Counter flow Cell (U.S. Patent No.s 5225065 and 5198094)
Accuracy:	Inert Mode: 4% of reading or ± 4 ppb, whichever is greater. H ₂ /O ₂ Mode: When the value is < 50 ppb, the accuracy is 6% of reading or ± 6 ppb, whichever is greater. When the value is >50 ppb, the accuracy is 2% of reading or ± 20 ppb, whichever is greater.
Alarms:	Two configurable alarms. Can be set anywhere within the operating range. Alternately, use it as a responsiveness check or gas trend indicator. One system alarm for cell responsiveness and flow.
Flow Control:	Provided by NIST traceable mass flow controllers. Required Flow: 1200 SCCM minimum
Low Detection Limit:	1 ppb at 95% Confidence Limit
Mounting:	Standard 7" X 19" Rack Mount for up to two TRACER 2 units
Environmental Conditions:	+10° to +40° Celsius +50° to +104° Fahrenheit 20% to 80% RH, non-condensing, non-corrosive atmosphere Optimal performance is achieved when temperature fluctuation is maintained below +/-2°C.
Power Requirements:	100-240 VAC, 50 watts
Sample Gas:	Air, Argon, Carbon Dioxide, Carbon Tetrafluoride†, Helium, Hydrogen, Methane†, Neon, Nitrogen, Krypton, Sulfur Hexafluoride, Oxygen, Xenon, non-corrosive/non-toxic gases. †these gases may require special handling. Please consult MEECO before use.
Sample Inlet Pressure:	30 – 150 psig (2 -10.2 Bar)** **For lower pressure, consult factory
Sensitivity:	0.5 ppb or below
Signal Output:	One 0-5V DC and 4-20m A analog output: user defined and scaled. RS-232 serial communication port, two level and one system alarm
User Interface:	2-line X 20 character Vacuum Fluorescent Display 5-key Membrane Keypad
Speed Response:	Response to 5 ppb intrusion is 50% in 15 minutes.
Configuration:	TRACER 2 DUO: Two TRACER 2s in one 7" X 19" rack mount box. .

*Specifications subject to change