

# Sentry® QCIII Quick Connect System

*The cleanest, safest, most user-friendly connection system available for high-purity bulk chemical dispense*

For more than 50 years, Entegris – the industry experts for materials integrity management solutions – has been committed to purifying, protecting and transporting the critical materials that enable the world's leading technologies. Materials integrity management starts with the chemicals that come into direct contact with every wafer and IC produced. To help you safely handle these high-purity, microelectronic-grade chemicals, Entegris offers the Sentry® QCIII quick connect system – a reliable means for filling containers or connecting a bulk chemical source to the chemical dispense unit.

## SENTRY QCIII QUICK CONNECT SYSTEMS

Entegris introduced our first patented Quick Connect System over 25 years ago and our system remains the industry standard for high-purity chemical dispense. Expanding on the proven performance and functionality of this quick connect system, the Sentry QCIII quick connect system is today's safest and easiest method of connecting chemical containers with typical bulk chemical delivery systems. This patented connection system comprises a key coded dispense head (DH3) and drum insert (DI3) that self align. Simply rotating the retaining ring pulls the DH3 and DI3 together so no visual line of site is required to make the connection – simplifying the assembly process significantly.

The Sentry QCIII quick connect system is designed for use with FluoroPure® chemical containers including HDPE transport drums, PFA composite drums, pressure vessels and intermediate bulk containers.



## O-ring Free Main Dispense Seal

The main chemical dispense line utilizes Entegris' industry leading Flaretek® sealing technology, which provides a leak-free, secure connection without o-rings. This sealing technology decreases your cost of ownership by eliminating the need for o-ring replacement and maintenance while minimizing downtime.



*The Sentry QCIII quick connect system is available with a 3-port or 4-port dispense head and a drum insert of either PFA or polyethylene material.*



*By utilizing Flaretek sealing technology in the main dispense line, Entegris has eliminated o-rings, reducing maintenance and decreasing cost of ownership.*

## Recirculation and Dispense in One

Designing four ports into the system enables recirculation and dispense operations in one connection. This eliminates the need for an independent recirculation dispense head and drum insert. The single dispense head connection assembles faster, requires less labor, reduces maintenance and lowers your costs.

1. The  $\frac{3}{4}$ " fill and dispense port allows higher flow in either filling or dispense applications
2. The  $\frac{1}{2}$ " vent port allows proper ventilation during chemical dispense operations
3. The  $\frac{1}{4}$ " connection verification port ensures proper DH3/DI3 engagement prior to initial dispense operations if OEM equipment is equipped with this feature
4. Optional  $\frac{3}{4}$ " recirculation port allows chemical recirculation; an optional diffuser, which reduces chemical agitation and foaming typical with chemicals containing surfactants

## Higher Flow Rates

Entegris' innovative dispense head optimizes the flow path to allow chemical dispense at 1.5x the flow rate of standard quick connect systems. This larger flow volume increases the overall capacity of your bulk chemical dispense system, reducing recirculation time and increasing process efficiency.

## EASY PRODUCT TRACEABILITY

Both the dispense head and drum insert are laser marked, allowing quick, visual identification. Permanent serialized laser marking is nonintrusive and noncontaminating. Laser marking allows for 100% traceability to a production date and production inspection record.



Permanent serialized laser marking on the dispense head, drum insert and ID tag allow for easy product identification and traceability.

## ASSEMBLY

### Attaching DH3 to DI3

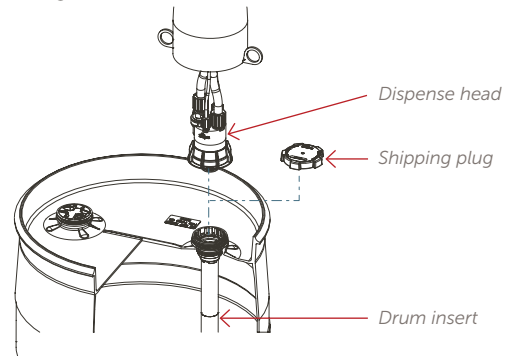

### DH3/DI3 Assembly Cross Sectional

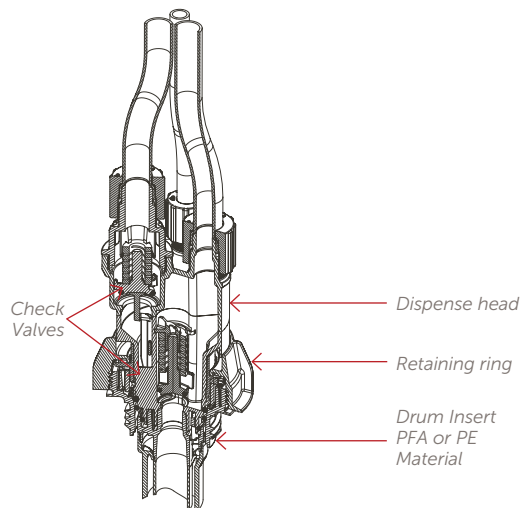

### Port Options

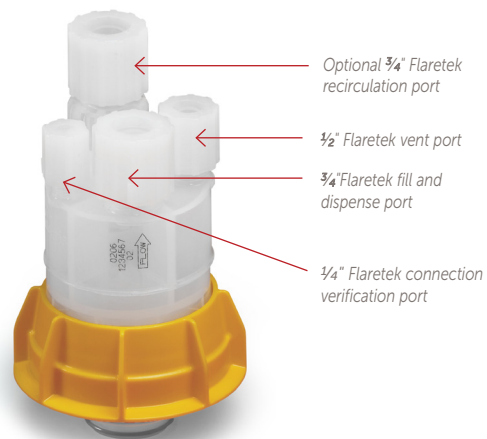

## KEY CODES

The Sentry quick connect system is the industry standard for interfacing FluoroPure containers with bulk chemical delivery systems safely and conveniently. Entegris' patented quick connect system is key coded to assure against unsafe chemical mixing while guaranteeing dedicated clean service. One connection provides dispensing, recirculation, venting and connection verification.



Entegris' patented quick connect system is key-coded to assure against unsafe chemical mixing.

### Drum Insert Key Code Tabs

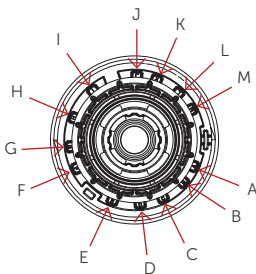

### Dispense Head Rotating Key Code Ring Notches

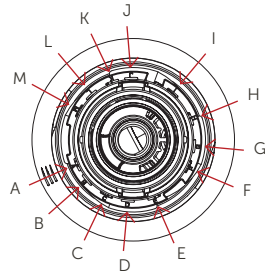

Due to the large quantity of key coded options, drum inserts are key coded per customer order.

A series of seven tabs/slots are used to make up each chemical code.

## PERFORMANCE DATA

### Dispense Port Water Flow vs. Pressure Drop

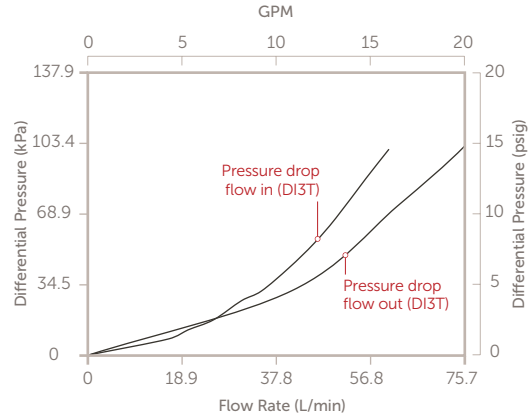

### Dispense Port Water Flow vs. Pressure Drop

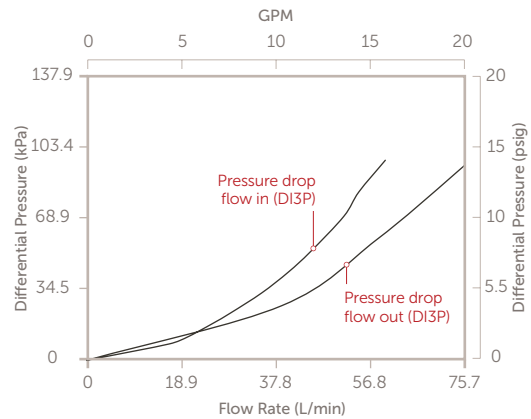

## SPECIFICATIONS

---

<b>Materials of construction</b>	Dispense head	Wetted parts include PFA, FEP and Kalrez® 4001 materials/Kalrez 6221 for Life Sciences applications
		Nonwetted parts are PFA and polyethylene
	Drum insert	Wetted parts are PFA or polyethylene with FEP encapsulated o-rings
		Nonwetted parts are polyethylene
<b>Operating conditions</b>	Maximum pressure	207 kPa (30 psig) @ 77°F (25°C)
<b>Life Science applications</b>	All internal wetted surfaces are made from resins that comply with FDA regulation 21 CFR 177.1550 or 21 CFR 177.2600 for use as articles or components of articles intended to contact food. Representative samples of these resins have been tested for biocompatibility in accordance with USP protocol and all meet the requirements of a USP Class VI (121 C) plastic. These resins also do not use any animal derived materials as intentional components.	

---

## ORDERING INFORMATION

Sentry QCIII Drum Inserts: part number

DI3 - - - -

### Special instructions

- 00 = Standard angle cut on downtube
- 01 = No angle cut on downtube

### DI tracking tag

- 0 = Standard serial number tag
- 1 = No tag

### O-ring material (shipping cap)

- 0 = FEP encapsulated silicone
- 1 = FEP encapsulated FKM
- 2 = FEP encapsulated EPDM

### Shipping cap

- 0 = Standard
- 3 = Manual relief
- 6 = Vented (H<sub>2</sub>O<sub>2</sub>)

### Chemical key code

Contact the factory for chemical codes assignments.

### Drum insert length

- 01 = 200 liter FluoroPure PFA composite drum
- 02 = 100 liter FluoroPure PFA composite drum
- 03 = 50 liter FluoroPure PFA composite drum
- 07 = 100 liter FluoroPure pressure vessel
- 08 = 20 liter FluoroPure pressure vessel
- 25 = 200 liter FluoroPure PGI Trilayer HDPE drum
- 28 = 20 liter FluoroPure PFA lined pail
- 29 = 55 gallon FluoroPure HDPE drum
- 1M = 200 liter FluoroPure Asia/Pacific HDPE drum
- 49 = 500 liter FluoroPure PE or PFA IBC
- 50 = 800 liter FluoroPure PE or PFA IBC
- 51 = 1200 liter FluoroPure PE or PFA IBC
- 53 = 175 liter FluoroPure PE/PE or PE/PFA composite drum
- XX = Contact the factory for additional assignments

### Number of ports

- 3 = Standard
- 4 = Includes recirculation diffuser

### Material of construction

- P = Polyethylene
- T = PFA

### Model

DI3 = QCIII drum insert

## Sentry QCIII Dispense Heads: part number

DH3 - - - -



### Special instructions

- 00 = Standard
- 01 = Dispense port without check valve
- 02 = Recirculation port without check valve
- 03 = No check valve in either dispense port or recirculation port

## Sentry QCIII Dispense Heads – Life Sciences: part number

01-1019894- -

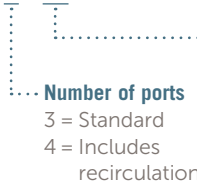

### Note:

Standard options include:

- FEP encapsulated silicone o-ring
- PFA nut material
- No tubing

Please contact Entegris if other options are necessary.

### FOR MORE INFORMATION

Please call your Regional Customer Service Center today to learn what Entegris can do for you. Visit [entegris.com](http://entegris.com) and select the [Contact Us](#) link to find the customer service center nearest you.

### TERMS AND CONDITIONS OF SALE

All purchases are subject to Entegris' Terms and Conditions of Sale. To view and print this information, visit [entegris.com](http://entegris.com) and select the [Terms & Conditions](#) link in the footer.



Corporate Headquarters  
129 Concord Road  
Billerica, MA 01821  
USA

Customer Service  
Tel +1 952 556 4181  
Fax +1 952 556 8022  
Toll Free 800 394 4083

Entegris®, the Entegris Rings Design®, and other product names are trademarks of Entegris, Inc. as listed on [entegris.com/trademarks](http://entegris.com/trademarks). All third-party product names, logos, and company names are trademarks or registered trademarks of their respective owners. Use of them does not imply any affiliation, sponsorship, or endorsement by the trademark owner.

©2006-2019 Entegris, Inc. | All rights reserved. | Printed in the USA | 3560-2438ENT-0819